

Model 1150

Špecifikácia

Model	11501CR 11502CR	11503CR 11504CR
Uhol otvorenia ramena:	89°	74°
Uhol otvorenia rukoväte:	159°	138°



11501CR
11503CR



11502CR
11504CR

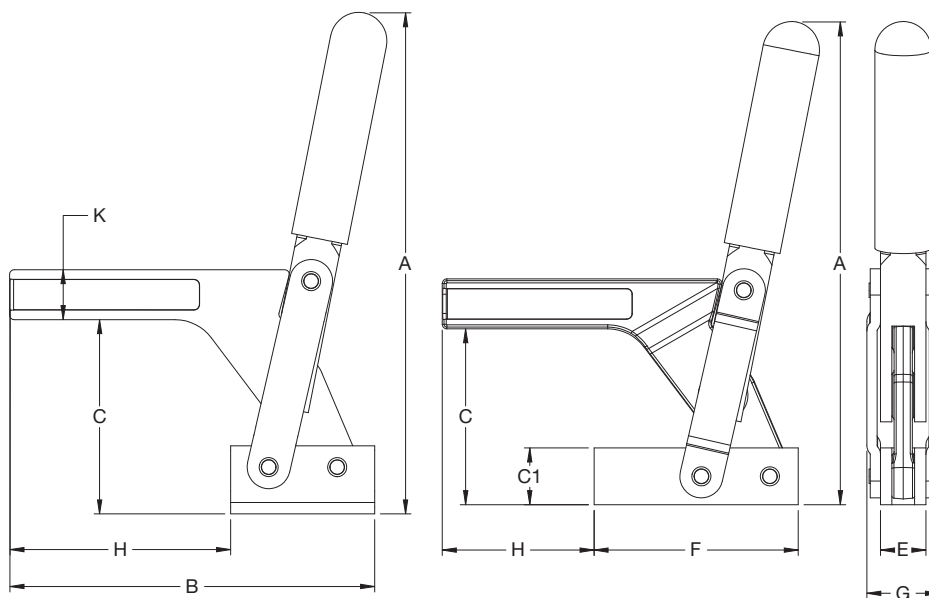
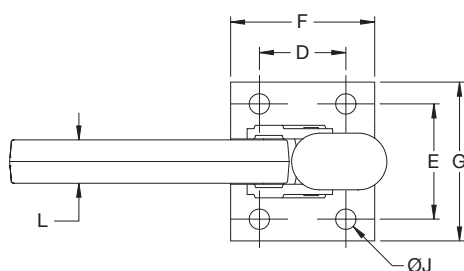

Model	Sila upnutia		Hmotnosť	A	B	C	C1	D	E	F	G	H	J	K	L
	N/lb.	Kg/lb.													
11501CR	3100	0.51	168.9	104.9	64.6	--	25.4	37	41.2	57	63.7	6.6	13	14.3	
	700	1.12	6.65	4.13	2.54	--	1.00	1.46	1.62	2.24	2.51	0.26	0.51	0.56	
11502CR	3100	0.48	168.9	102.7	54.3	15	--	15	63.5	25	39.2	--	13	14.3	
	700	1.06	6.65	4.04	2.14	0.59	--	0.59	2.5	0.98	1.54	--	0.51	.56	
11503CR	5100	1.35	220.9	160.9	85.6	--	38.1	50.8	63.5	70	97.4	9	22	19.1	
	1150	2.98	8.7	6.33	3.37	--	1.50	2.00	2.50	2.76	3.83	0.35	0.87	0.75	
11504CR	5100	1.34	212.8	156.9	77.5	25	--	20	90	32	66.9	--	22	19.1	
	1150	2.95	8.38	6.18	3.02	0.98	--	0.79	3.54	1.26	2.63	--	0.87	0.75	

Model 1159

Špecifikácia

Model	11591CR 11592CR	11593CR 11594CR	11595CR
Uhol otvorenia ramena:	135°	132°	147°
Uhol otvorenia rukoväte:	70°	71°	74°

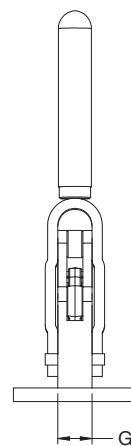
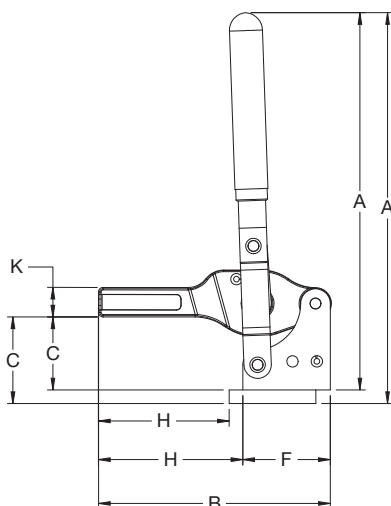
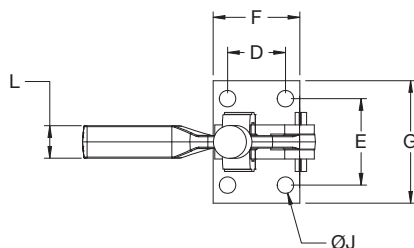
11591CR
11593CR
11595CR11592CR
11594CR

Model	Sila upnutia		Hmotnosť	A	B	C	D	E	F	G	H	J	K	L
	N/lb.	Kg/lb.												
11591CR	3340	0.49	172.3	101.7	38.2	25.4	38.1	38.0	54.0	57.4	7.3	13.0	14.3	
	750	1.08	6.78	4.00	1.50	1.00	1.50	1.50	2.13	2.26	0.29	0.51	0.56	
11592CR	3340	0.37	166.3	101.7	32.2	--	--	38.4	15.0	63.3	--	13.0	14.3	
	750	0.82	6.55	4.00	1.27	--	--	1.51	0.59	2.49	--	0.51	0.56	
11593CR	7120	1.29	232.7	152.5	50.5	38.1	50.8	57.0	70.0	89.2	10.5	19.0	19.0	
	1600	2.84	9.16	6.00	1.99	1.50	2.00	2.24	2.76	3.51	0.41	0.75	0.75	
11594CR	7120	1.02	226.7	152.5	44.5	--	--	57.1	19.0	95.4	--	19.0	19.0	
	1600	2.24	8.93	6.00	1.75	--	--	2.25	0.75	3.76	--	0.75	0.75	
11595CR	12230	2.92	285.7	203.0	69.3	50.8	69.9	75.0	98.5	118.5	14.0	25.4	25.4	
	2750	6.44	11.25	7.99	2.73	2.00	2.75	2.95	3.88	4.66	0.55	1.00	1.00	

Model 1350

Špecifikácia

Model	13501CRM 13502CRM	13503CRM 13504CRM	13505CRM 13506CRM	13507CRM 13508CRM
Zdvih:	44.5 [1.75]	25.4 [1.00]	79.5 [3.13]	48.3 [1.9]
Uhol otvorenia rukoväte:	125°	113°	139°	125°

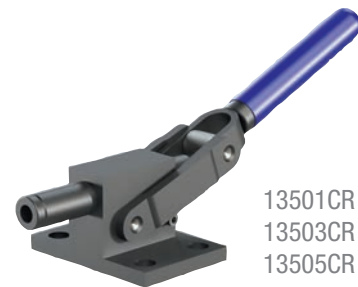

13501CR
13503CR
13505CR

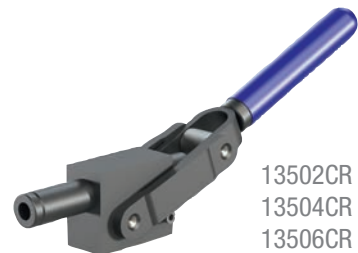

13502CR
13504CR
13506CR



13507CR



13508CR

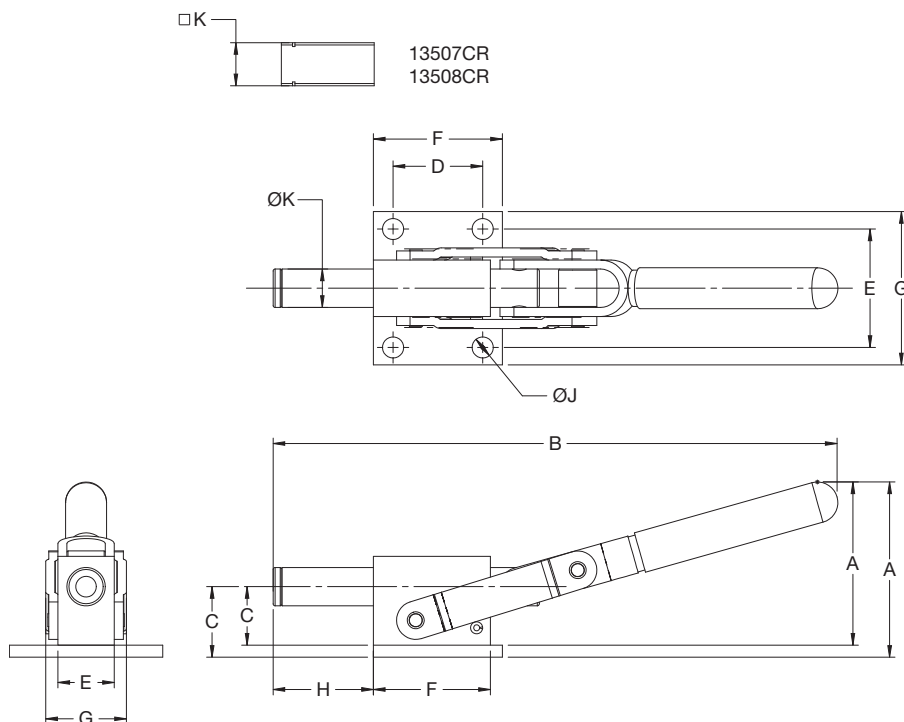

Model	Sila upnutia		Hmotnosť	A	B	C	D	E	F	G	H	J	K
	N/lb.	Kg/lb.											
13501CRM	25800	1.30	86.9	279.7	35	44.5	58.7	64	76	49.7	10.5	19	
	5800	2.87	3.42	11.01	1.38	1.75	2.31	2.52	2.99	1.96	0.41	0.75	
13502CRM	25800	1.09	80.9	279.7	29	--	28	58	40	49.7	--	19	
	5800	2.40	3.19	11.01	1.14	--	1.10	2.28	1.57	1.96	--	0.75	
13503CRM	11120	0.51	63.2	193.5	28	28.6	47.6	44	64	29.3	8.6	13	
	2500	1.12	2.49	7.62	1.10	1.13	1.87	1.73	2.52	1.15	0.34	0.51	
13504CRM	11120	0.39	57.2	193.5	22	--	19	38.5	29	29.3	--	13	
	2500	0.85	2.25	7.62	0.87	--	0.75	1.52	1.14	1.15	--	0.51	
13505CRM	20460	1.41	92.1	328.5	35	44.50	58.7	64.00	76	82.2	10.5	19.0	
	4600	3.12	3.63	12.93	1.38	1.75	2.31	2.52	2.99	3.24	0.41	0.75	
13506CRM	20460	1.20	86.1	328.5	29	--	28	60.50	39	82.2	--	19.0	
	4600	2.65	3.39	12.93	1.14	--	1.10	2.38	1.54	3.24	--	0.75	
13507CRM	25800	0.51	86.9	282.6	35	44.50	58.7	64.0	76	49.7	10.5	19.0	
	5800	1.12	3.42	11.13	1.38	1.75	2.31	2.52	2.99	1.96	0.41	0.75	
13508CRM	25800	0.39	80.9	282.6	29	--	28	60.50	40	49.7	10.5	19.0	
	5800	0.85	3.19	11.13	1.14	--	1.1	2.38	1.57	1.96	0.41	0.75	

Model 1450

Špecifikácia

Uhol otvorenia ramena: 90°

Uhol otvorenia rukoväte: 69°

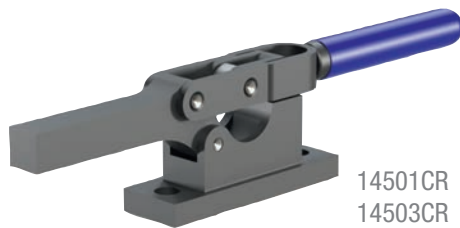
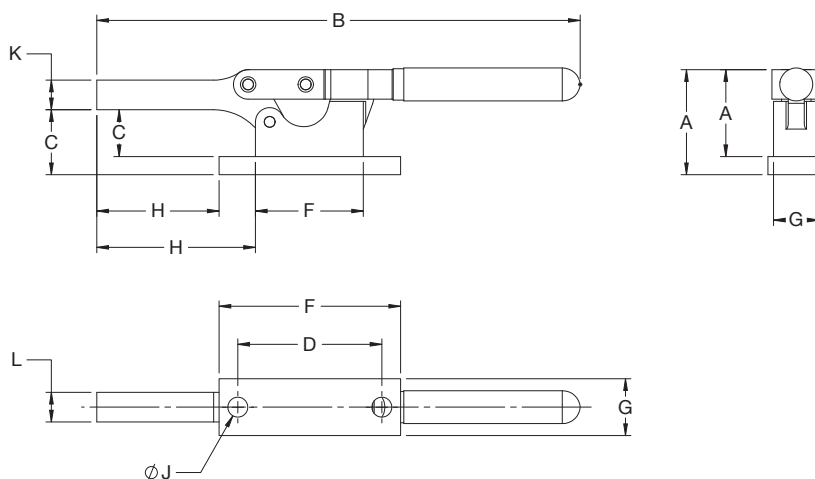
14501CR
14503CR14502CR
14504CR

Model	Sila upnutia		A	B	C	D	F	G	H	J	K	L
	N/lb.	Kg/lb.										
14501CR	2670	0.49	47.1	213.1	28.7	63.5	80	25	69.9	8.8	13	13
	600	1.08	1.85	8.39	1.13	2.50	3.15	0.98	2.75	0.35	0.51	0.51
14502CR	2670	0.37	39.1	213.1	20.7	--	47.6	20	53.9	--	13	13
	600	0.82	1.54	8.39	0.81	--	1.87	0.79	2.12	--	0.51	0.51
14503CR	5780	1.29	59.6	279.6	33.4	92.1	117.5	38.1	66.7	10.3	19.1	20
	1300	2.84	2.34	11.01	1.32	3.63	4.63	1.5	2.63	0.41	0.75	0.79
14504CR	5780	1.02	51.6	279.6	25.4	--	66.7	28.6	92.1	--	19.1	20
	1300	2.24	2.03	11.01	1.00	--	2.63	1.13	3.63	--	0.75	0.79